

Close Wed: HW_3A,3B,3C

(complete sooner!)

Exam 1 is Thurs (4.9, 5.1-5.5, 6.1-6.3)

Entry Task:

Consider the region R bounded by $y = x^3$, $y = 8$, and $x = 0$.

Set up the integrals that would give the volume of the solid obtained by rotating R about the ...

- (a) ... x -axis.
- (b) ... y -axis.
- (c) ... vertical line $x = -10$.

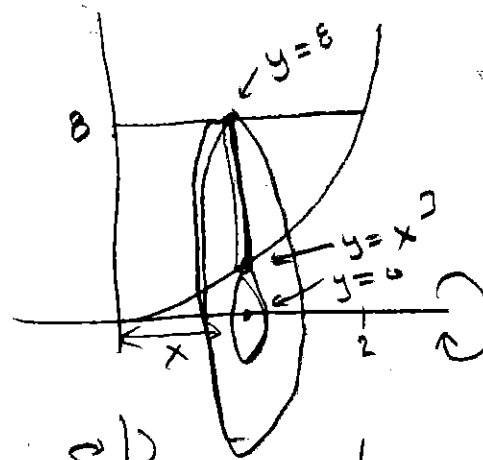

$$\int_0^2 \pi(8^2 - \pi(x^3)^2) dx$$
$$\pi \int_0^2 64 - x^6 dx$$

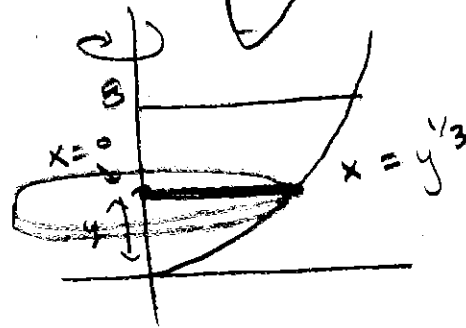

$$\int_0^8 \pi (y^{1/3})^2 dy$$
$$= \pi \int_0^8 y^{2/3} dy$$

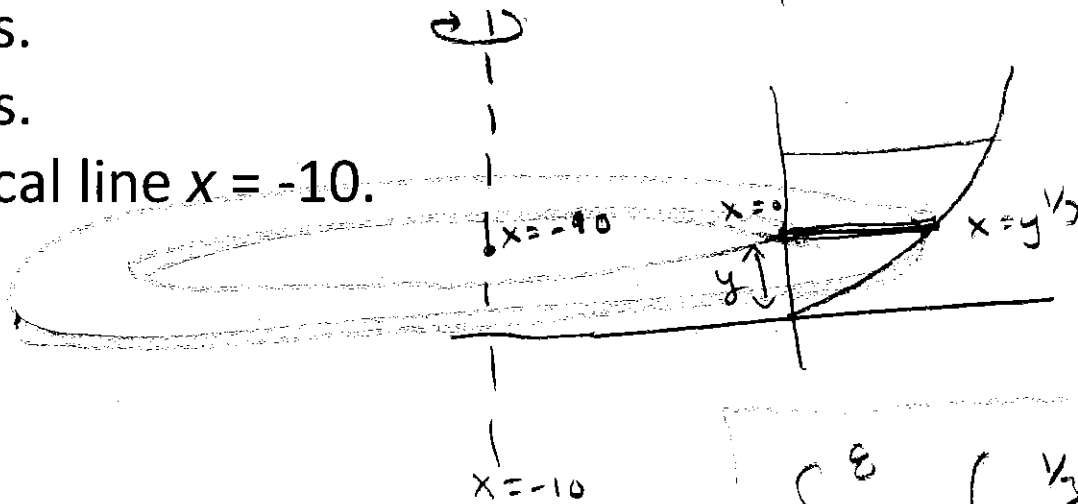

$$\int_0^8 \pi (y^{1/3} + 10)^2 - \pi(10)^2 dy$$

Example:

Let R be the region bounded by

$$y = \frac{1}{x^2} + \frac{1}{x}, y = 0, x = 1, x = 2.$$

Consider the solid obtained by rotating about the **y-axis**.

Try to use cross-sectional slicing...
why is this difficult/messy?

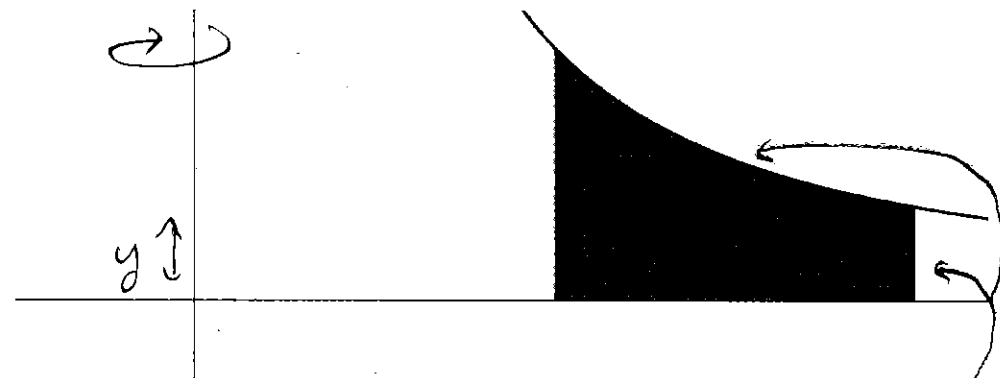

① "RIGHT" EQUATION CHANGES!

② IT IS DIFFICULT/MESSY TO
SOLVE FOR x IN TERMS
OF y (IT IS POSSIBLE)

$$\int \pi (\quad)^2 - \pi (\quad)^2 dy$$

WE WOULD PREFER TO USE x !

5.3 Volumes Using Cylindrical Shells

Visual Motivation:

Consider the solid

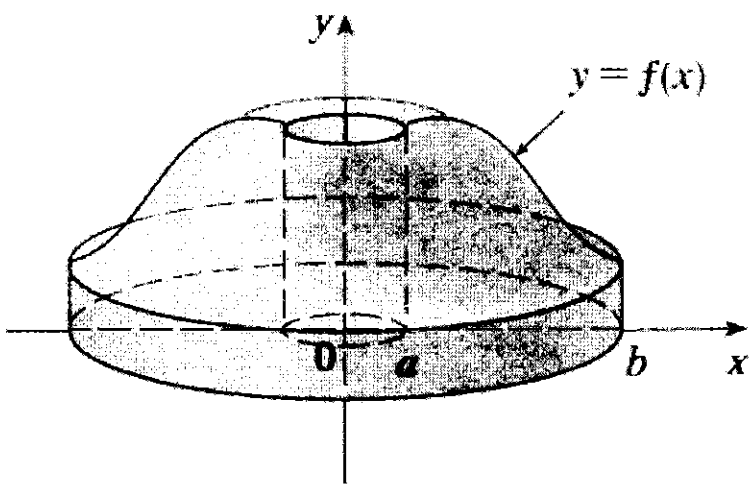
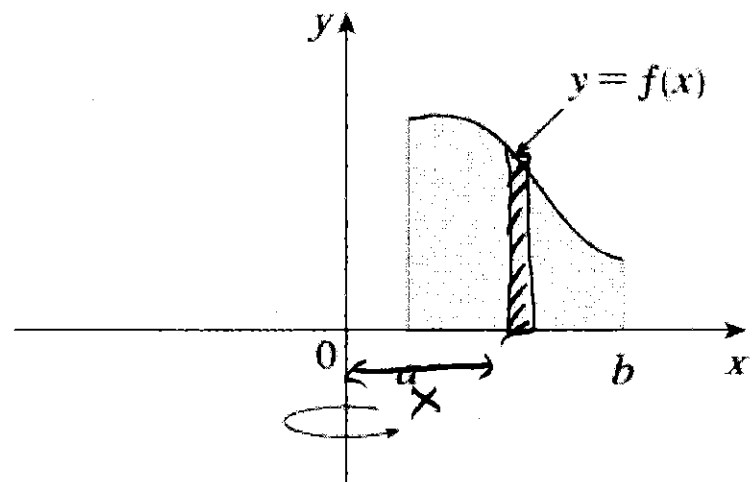

We want to use “ dx ”, but that breaks the region into thin vertical subdivisions and rotating those gives a new shape, “cylindrical shells”

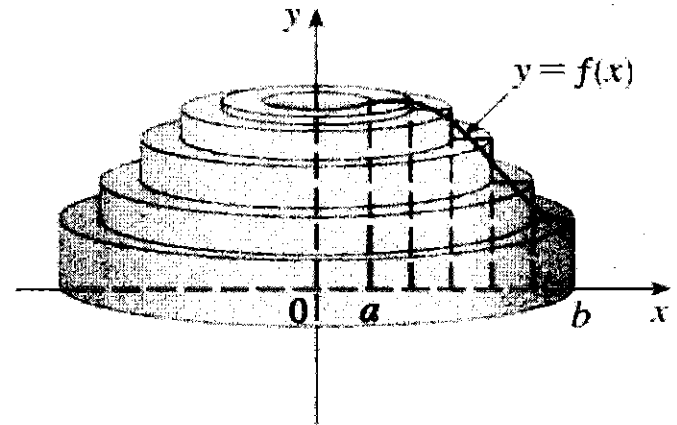
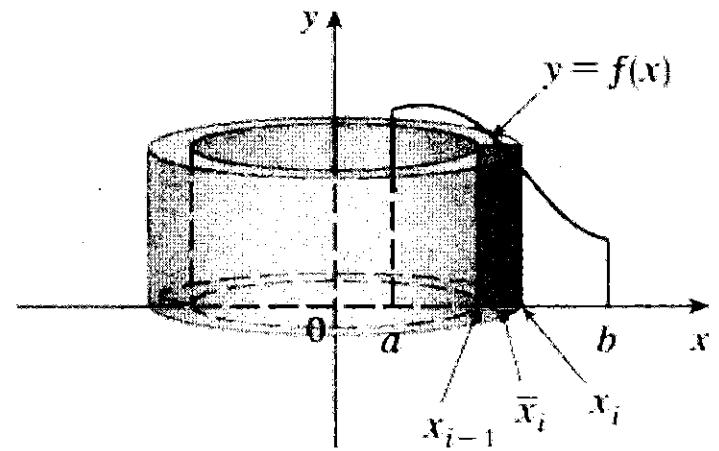

Derivation:

The pattern for the volume of one thin cylindrical shell is

$$\begin{aligned} \text{VOLUME} &\approx (\text{surface area})(\text{thickness}) \\ &= SA(x_i) \Delta x \\ &= 2\pi(\text{radius})(\text{height})(\text{thickness}) \end{aligned}$$

$$\begin{aligned} \text{Volume} &= \int_a^b SA(x) dx \\ &= \int_a^b 2\pi(\text{radius})(\text{height}) dx \end{aligned}$$

Thus, if we can find a formula, $SA(x_i)$, for the surface area of a typical cylindrical shell, then

$$\text{Thin Shell Volume} \approx SA(x_i) \Delta x,$$

$$\text{Total Volume} \approx \sum_{i=1}^n SA(x_i) \Delta x$$

$$\text{Exact Volume} = \lim_{n \rightarrow \infty} \sum_{i=1}^n SA(x_i) \Delta x$$

Volume using cylindrical shells

1. Draw region. Cut **parallel** to rotation axis. Label x if that cut crosses the x -axis (and y if y -axis). Label **everything** in terms this variable.

2. Formula for surface area of cylindrical shell?

$$\begin{aligned} \text{SA} &= (\text{Circumference})(\text{Height}) \\ &= 2\pi(\text{Radius})(\text{Height}) \end{aligned}$$

3. Integrate the SA formula.

Example:

Let R be the region bounded by

$$y = \frac{1}{x^2} + \frac{1}{x}, y = 0, x = 1, x = 2.$$

Set up an integral for the volume obtained by rotating R about the **y -axis**.

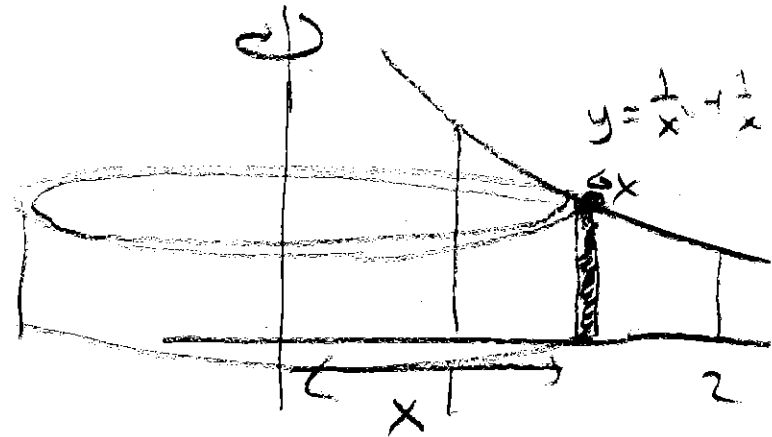

$$\int_1^2 2\pi (x) \left(\frac{1}{x^2} + \frac{1}{x} \right) dx$$

$$2\pi \int_1^2 \frac{1}{x} + 1 dx$$

$$2\pi \left(\ln|x| + x \Big|_1^2 \right)$$

$$2\pi \left((\ln(2) + 2) - (\ln(1) + 1) \right) =$$

$$\boxed{2\pi (\ln(2) + 1)}$$

Example: Let R be the region in the first quadrant that is bounded by

$$x = \sqrt{y+1} \text{ and } y = 1.$$

Find the volume obtained by rotating R about the x -axis.

$$y = x^2 - 1$$

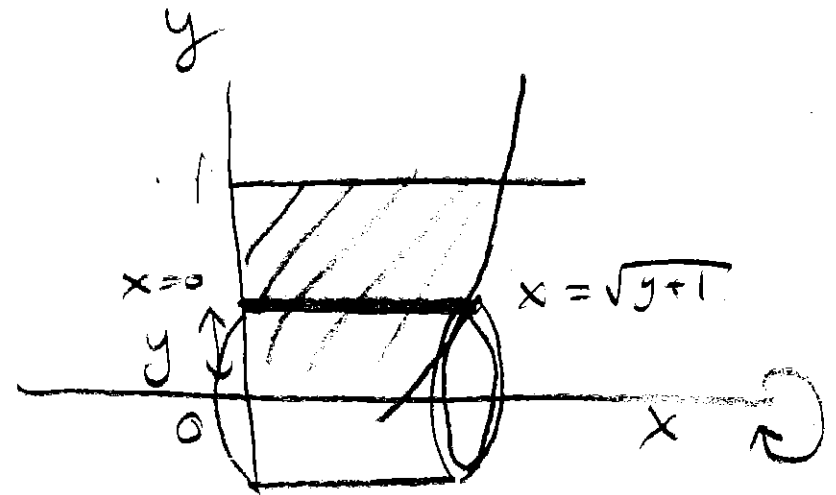

WANT TO USE dy !!! (BOTTOM CHANGES)

$$\int_0^1 2\pi (y) (\sqrt{y+1}) dy$$

$$2\pi \int_0^1 y \sqrt{y+1} dy$$

← substitution!

$$2\pi \int_1^2 (u-1) \sqrt{u} du$$

$$u = y+1 \Leftrightarrow y = u-1 \\ du = dy$$

$$2\pi \int_1^2 u^{3/2} - u^{1/2} du$$

$$2\pi \left(\frac{2}{5} u^{5/2} - \frac{2}{3} u^{3/2} \Big|_1^2 \right) = 2\pi \left[\left(\frac{2}{5} (2)^{5/2} - \frac{2}{3} (2)^{3/2} \right) - \left(\frac{2}{5} - \frac{2}{3} \right) \right]$$

Flow chart of all Volume of Revolution Problems

Step 0: Draw an accurate picture!!! (Always draw a picture)

Step 1: Choose and label the variable (based on the region and given equations)

If x , draw a typical **vertical** thin approximating rectangle at x .

If y , draw a typical **horizontal** thin approximating rectangle at y .

Step 2: Is the approximating rectangle perpendicular or parallel to the rotation axis?

Perpendicular → *Cross-sections:*

$$\text{Volume} = \int_a^b (\pi(\text{outer})^2 - \pi(\text{inner})^2)(dx \text{ or } dy)$$

Parallel → *Shells:*

$$\text{Volume} = \int_a^b 2\pi(\text{radius})(\text{height})(dx \text{ or } dy)$$

Step 3: Write everything in terms of the desired variable and fill in patterns.

Then integrate.

The above method is how you should approach problems, but if you are still having trouble seeing which variable goes with which method here is a summary:

Axis of rotation	Disc/Washer	Shells
x-axis (or any horizontal axis)	dx	dy
y-axis (or any vertical axis)	dy	dx

Example:

Let R be the region bounded by $y = x^3$, $y = 4x$ between $x = 1$ and $x = 2$.

1. Set up an integral for the volume of the solid obtained by rotating R **about the y-axis**.

$$\int_1^2 2\pi(x)(4x - x^3) dx$$

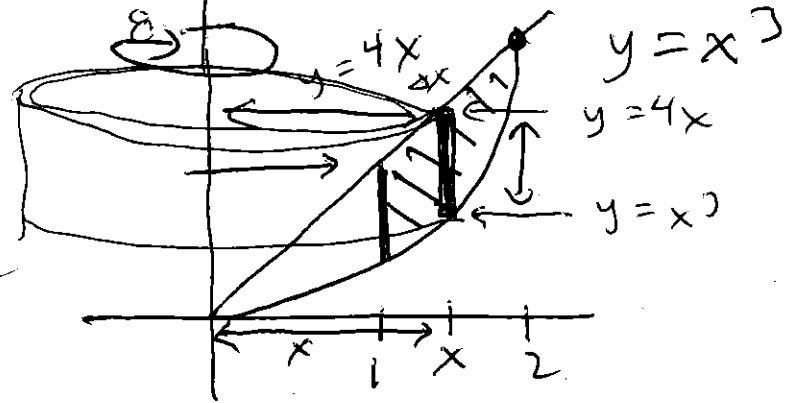

2. Set up an integral for the volume of the solid obtained by rotating R **about the x-axis**.

$$\int_1^2 \pi(4x)^2 - \pi(x^3)^2 dx$$

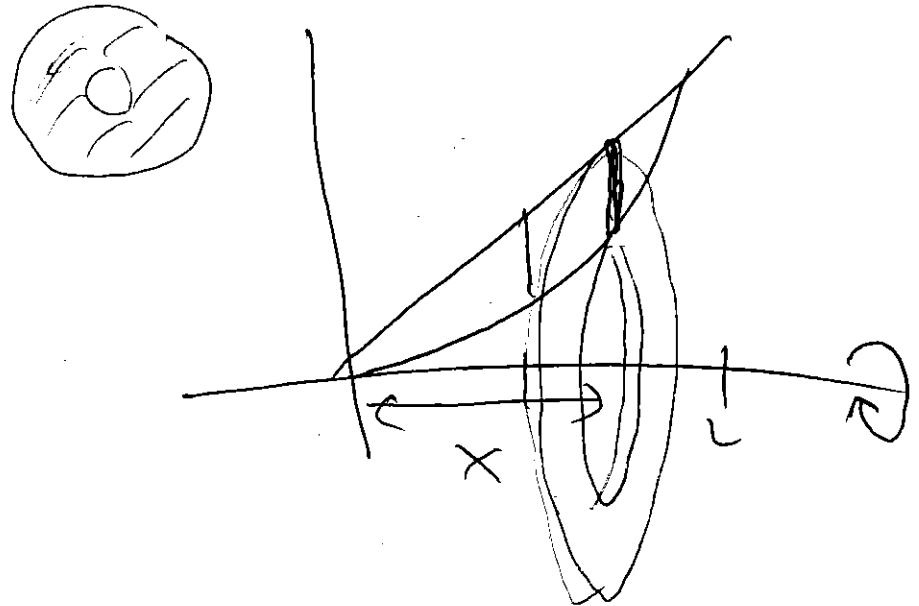

3. Set up an integral for the volume of the solid obtained by rotating R about the vertical line $x=3$.

$$\int_0^2 2\pi(3-x)(4x-x^2) dx$$

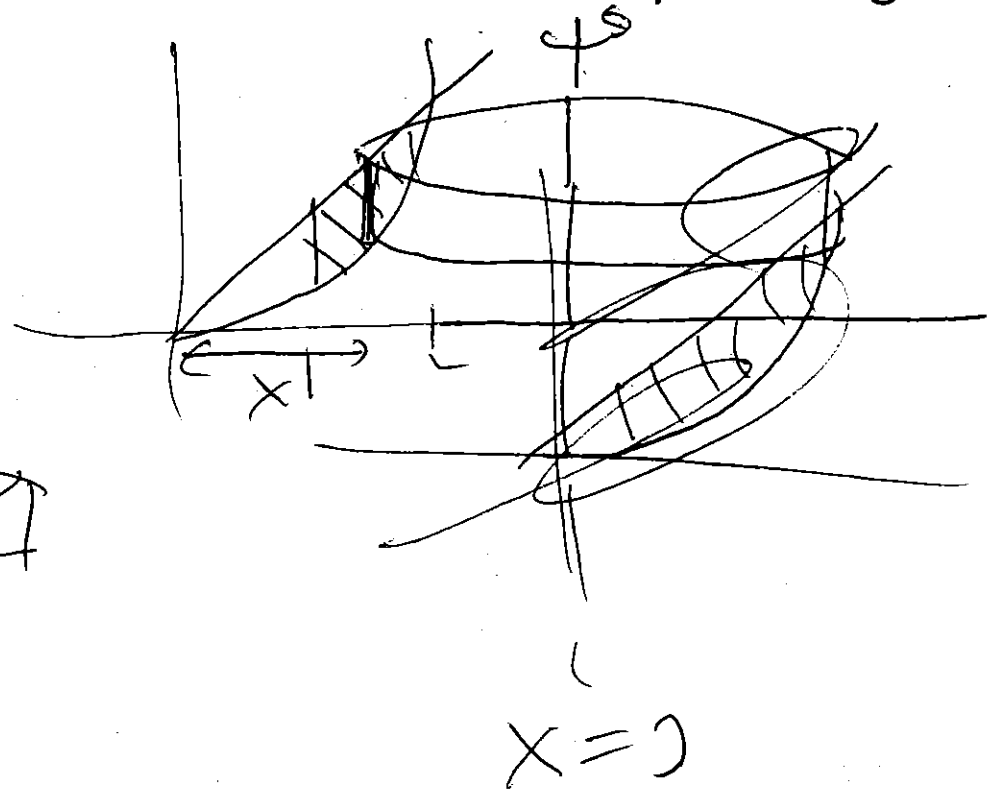
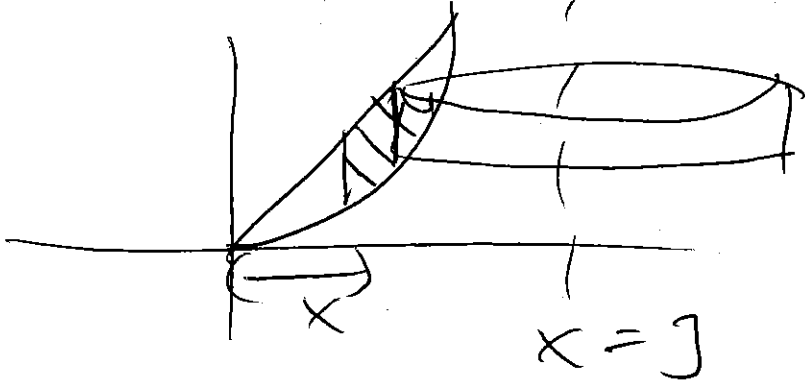

Math 125 - Spring 2017

Exam 1

April 20, 2017

Name: _____

Section: _____

Student ID Number: _____

PAGE 1	12	
PAGE 2	12	
PAGE 3	12	
PAGE 4	12	
PAGE 5	12	
Total	60	

- There are 5 pages of questions. Make sure your exam contains all these questions.
- You are allowed to use a Ti-30x IIS Calculator model **ONLY** (**no other calculators allowed**). And you are allowed one **hand-written** 8.5 by 11 inch page of notes (front and back).
- Leave your answer in exact form. Simplify standard trig, inverse trig, natural logarithm, and root values. Here are several examples: you should write $\sqrt{4} = 2$ and $\cos\left(\frac{\pi}{6}\right) = \frac{\sqrt{3}}{2}$ and $\frac{7}{2} - \frac{3}{5} = \frac{29}{10}$ and $\ln(1) = 0$ and $\tan^{-1}(1) = \frac{\pi}{4}$.
- Show your work on all problems. The correct answer with no supporting work may result in no credit. **Put a box around your FINAL ANSWER for each problem and cross out any work that you don't want to be graded.**
- If you need more room, use backs of the pages and indicate to the grader that you have done so.
- Raise your hand if you have a question.
- There may be multiple versions of the exam so if you copy off a neighbor and put down the answers from another version we will know you cheated. Any student found engaging in academic misconduct will receive a score of 0 on this exam. All suspicious behavior will be reported to the student misconduct board.
DO NOT CHEAT OR DO ANYTHING THAT LOOKS SUSPICIOUS!
WE WILL REPORT YOU AND YOU MAY BE EXPELLED!
Keep your eyes down and on your paper. If your TA sees your eyes wandering they will warn you only once before taking your exam from you.
- You have 80 minutes to complete the exam. Budget your time wisely.
SPEND NO MORE THAN 10 MINUTES PER PAGE!

GOOD LUCK!

1. (12 pts) Evaluate the integrals. If you do a substitution, you *must* show that you know how to appropriately change bounds for full credit.

(a) $\int \frac{4}{\sqrt{x}} + x^4 \left(\frac{3}{4x^5} - \frac{x^2}{2} \right) + \sec^2(5x) dx$

(b) $\int_{\pi/3}^{\pi/2} \sin(x)e^{6\cos(x)} dx$

2. (12 pts) Evaluate the integrals. If you do a substitution, you *must* show that you know how to appropriately change bounds for full credit.

(a) $\int \frac{e^{8x}}{(e^{4x} + 5)^2} dx$

(b) $\int_{-3}^1 x\sqrt{x+3} dx$

3. (12 pts)

(a) Let $f(x) = \int_{5x+\cos(x)}^{32} \frac{4}{\sqrt{8+t}} dt$. Find $f'(0)$.

(b) At t seconds, a particle is moving on a line with velocity $h'(t) = v(t) = 8t(t^2 - 1)^3$ ft/sec. At time $t = 2$ seconds, the particle is at a height of 10 ft (*i.e.* $h(2) = 10$).

i. Find the function, $h(t)$, for the height of the particle at time t seconds.

ii. Find the **total distance** traveled by the particle from $t = 0$ to $t = 2$ seconds.

4. (12 pts)

(a) Consider the region bounded by $y = 6x$ and $y = x^2$ from $x = 0$ to $x = 6$.

i. Give the integral in terms of x for the area of this region. (DO NOT EVALUATE)

ii. Approximate the area using $n = 3$ approximating rectangles and right endpoints (don't simplify, leave your answer expanded out).

iii. Give the pattern, in terms of i and n , for the right endpoint approximation for this area with n subdivisions.

Answer (enter pattern here): $\sum_{i=1}^n$

(b) At time $t = 0$ seconds, you are standing on a bridge directly above Dr. Loveless and throw a small water balloon. It hits Dr. Loveless in 2 seconds with a downward speed of 75 feet/sec at the instant it hits him. Assume the balloon accelerates downward at a constant 32 feet/sec². At what height was the balloon exactly 1 second after you threw it?

5. (12 pts) Let R be the region bounded by $y = x^3$, the **horizontal** line $y = 8$, and the y -axis.

- (a) Find the value of the constant b such that the **horizontal** line $y = b$ would divide the region R into two regions of equal area.

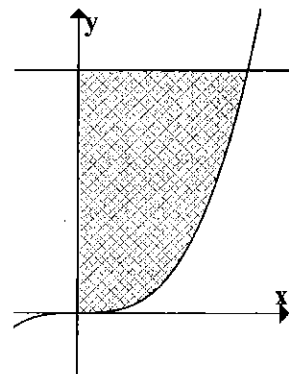

- (b) Find the volume of the solid obtained by rotating the region R about the y -axis. Set up AND evaluate. (Use any correct method)

- (c) A solid is obtained by rotating the region R around the **horizontal** line $y = -1$. Set up the integrals you get for the volume of this solid using BOTH the method of cylindrical shells and the method of washers (DO NOT EVALUATE).

Shells:

Washers: